

## Dear partners and home owners,

Thankyou for your interest in an AGS Systems product, by THEINVISIBLETOOLBOX. In the following pages, you will find a compilation of all technical matters of relevance from the manufacturers of the Frame system.

### Content:

- TCG - Extrusion - A dimensioned Section view \_\_\_\_\_ Page 2
- TCG - Technical Specifications \_\_\_\_\_ Page 3
- TCG - Installation instructions \_\_\_\_\_ Page 6
- TCG - Generic application details by AGS \_\_\_\_\_ Page 20

AGS solutions are of the highest technical credibility, and manufactured to excellent quality control standards.

The products are designed for easy installation, and a durable, beautiful result.

Installation details pertaining to any particular project may vary.

We encourage you to get in touch with us with any technical question: THEINVISIBLETOOLBOX will be happy to take your wall assembly specific requirements, and offer you a suitable CAD detail for an architectural application, where the relevant profile is detailed into your construction.

THEINVISIBLETOOLBOX, delivers technical support and sales services for the AGS product line in Canada. We are happy to be of service, to include sales support, guidance to tradesmen as well as take on complete door projects.

We look forward to hearing from you,  
and taking part in your future opening challenges!  
Best, THEINVISIBLETOOLBOX team.

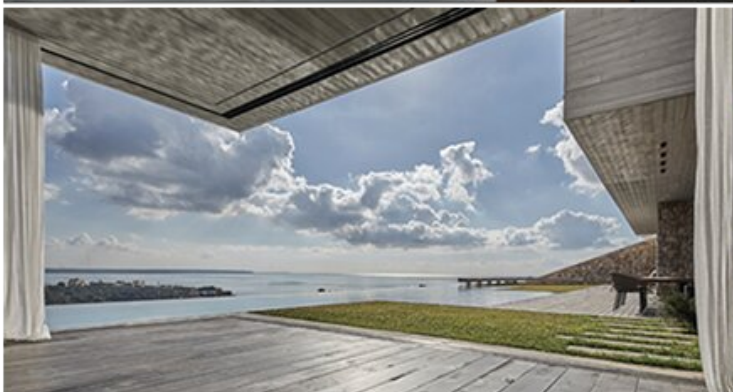

**THEINVISIBLETOOLBOX**  
SOUND PRINCIPLES FOR MINIMAL CONSTRUCTION  
By KOMETSEISE Inc. #36 Alberta Ave, Toronto Ontario. M6H-2R6  
WWW.THEINVISIBLETOOLBOX.CA WWW.KOMETSEISE.COM  
INFO@THEINVISIBLETOOLBOX.CA Phone: 647 500 4103



FOR ANY TECHNICAL QUESTIONS PLEASE CONTACT-

AGS Systems - Canada  
By THEINVISIBLETOOLBOX  
PH. 647.5004103  
E. INFO@THEINVISIBLETOOLBOX.CA  
WWW.THEINVISIBLETOOLBOX.CA  
36 ALBERTA AVE. TORONTO ONTARIO. M6H-2R6,  
CANADA.

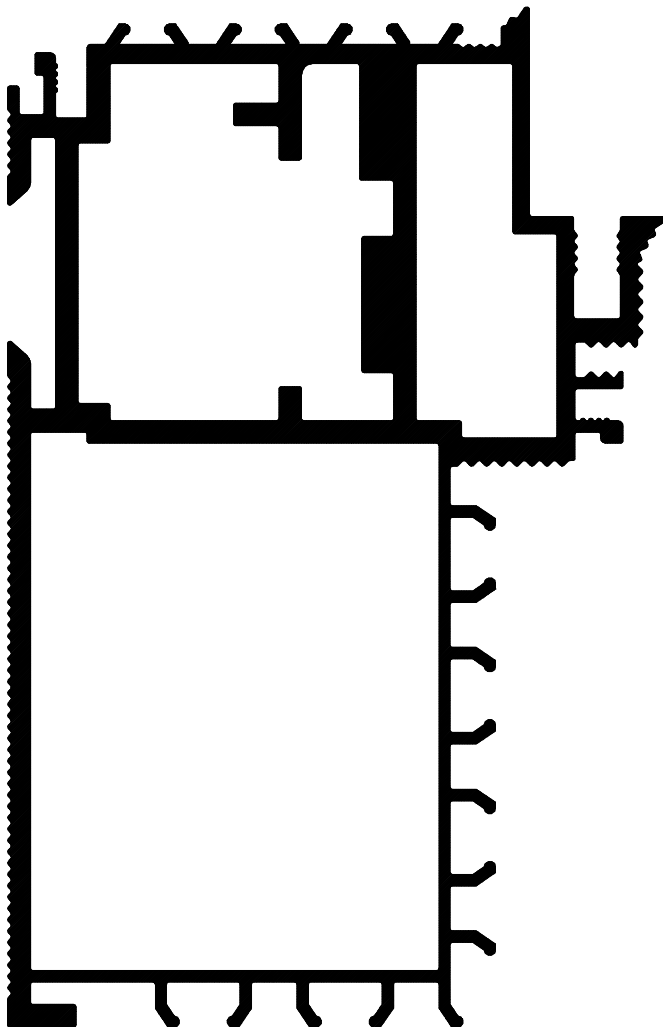
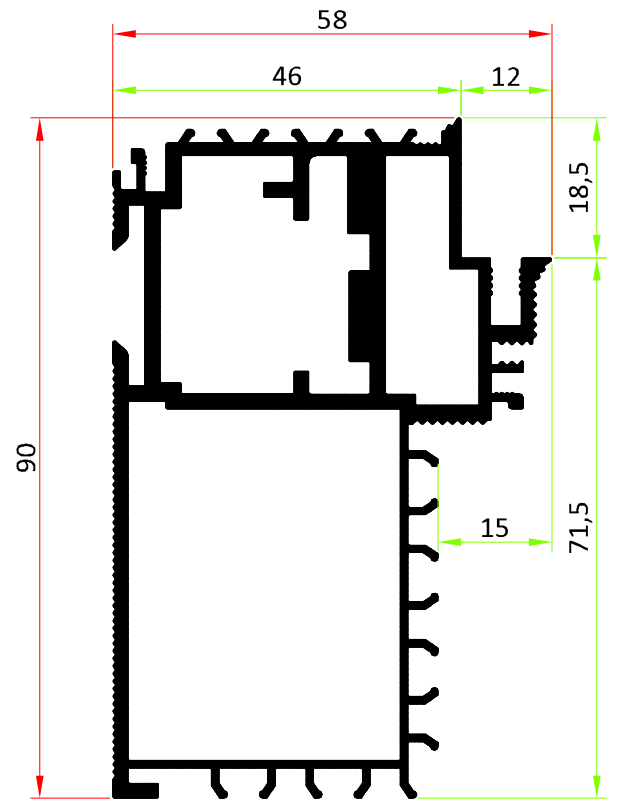

AGS-Systems - 39025 Naturno (Italy)		
Drawing	TCG Art.nr. 10160	
Scala 1:1	Date	30 01 2018
	Modified	

Technical data sheet

**Model TCG  
 for all-glass doors**

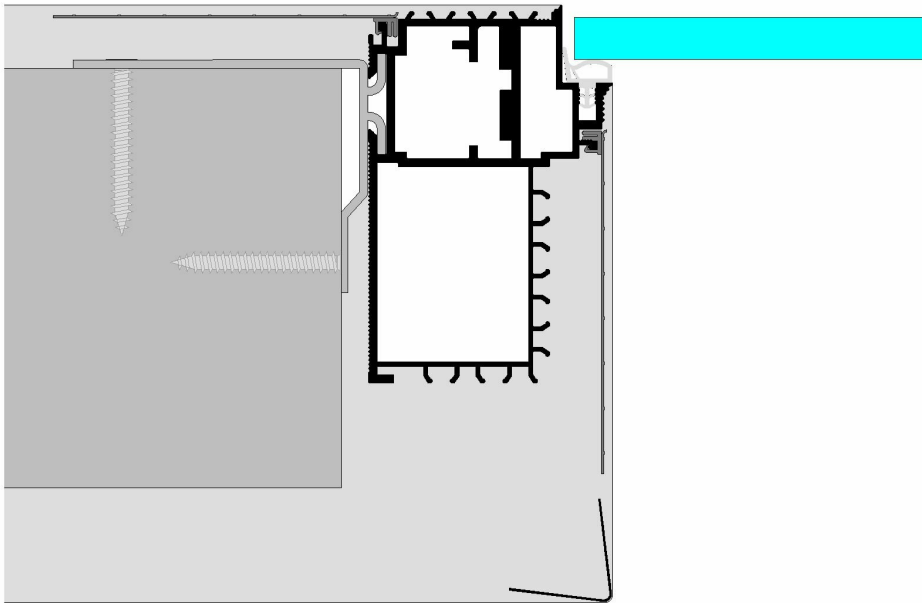

By  
**THEINVISIBLETOOLBOX.ca**  
 SOUND PRINCIPLES FOR MINIMAL CONSTRUCTION  
 By KOMETSENSE Inc. #36 Alberta Ave, Toronto Ontario. M6H-2R6  
 WWW.THEINVISIBLETOOLBOX.CA WWW.KOMETSENSE.COM  
 INFO@THEINVISIBLETOOLBOX.CA Phone: 647.500.4103

**Index**

Profile detail..... 2

Recommendations..... 3

    Suitable hinges..... 3

    Suitable closing plates..... 3

    Suitable seals..... 3

## Profile detail

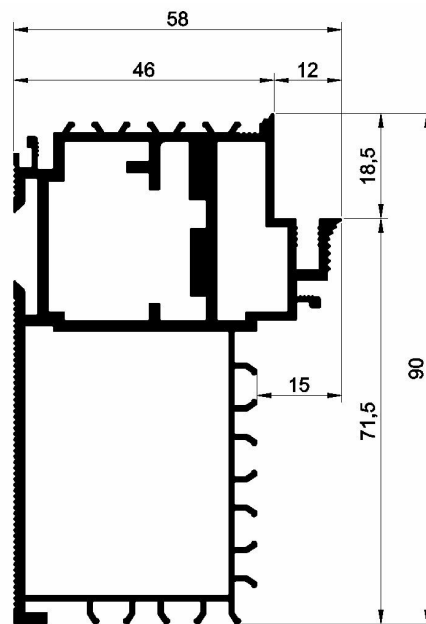

### Model TCG

#### Suitable solid and dry construction

The frame profiles are supplied mitre-cut to suit door size, and machined to suit concealed hinges, lock strikes and other hardware. In combination with the snap-in corner connectors and the mounting brackets, this enables quick assembly and professional installation. The snap-in mesh ensures no plaster cracks between wall and frame. Suits standard or floor-to-ceiling doors. Suits standard or floor-to-ceiling all-glass doors of 8 and 10 mm.

## Recommendations

On the basis of detailed tests and long-term experiences our technical office has prepared a recommendation list regarding the selection of hinges, closing panels and seals. This lists are practical guidelines and non exhaustive.

<b>Suitable hinges</b>	
<i>Description</i>	<i>Weight</i>
Simonswerk Tectus TEG 3102D <a href="http://www.simonswerk.com">www.simonswerk.com</a>	60 kg

<b>Suitable closing panels</b>	
<i>Name</i>	<i>Description striking plate</i>
Simonswerk <a href="http://www.simonswerk.com">www.simonswerk.com</a>	KC 50

<b>Suitable seals/gaskets</b>	
<i>Producer</i>	<i>Item number</i>
Helmut Goll GmbH	A1022
Deventer Profile GmbH	DS 6577a
Deventer Profile GmbH	S 6577a
Deventer Profile GmbH	S 7381
Deventer Profile GmbH	SP 7677
Primo Profile GmbH	AC-5990
Schlegel GmbH	QL 3113

We guarantee for a high quality of our products. Our processing guidelines are based on tests and practical experiences; they are only indication without assurance of properties, we have no influence on condition of construction sites and the realizations of the works

Country specific regulations, which consist on regional standards, building regulations, processing and industrial guidelines, can guide to specific processing recommendations.

FOR ANY TECHNICAL QUESTIONS PLEASE CONTACT-

AGS Systems - Canada

By THEINVISIBLETOOLBOX

PH. 647.5004103

E. INFO@THEINVISIBLETOOLBOX.CA

WWW.THEINVISIBLETOOLBOX.CA

36 ALBERTA AVE. TORONTO ONTARIO. M6H-2R6,  
CANADA.

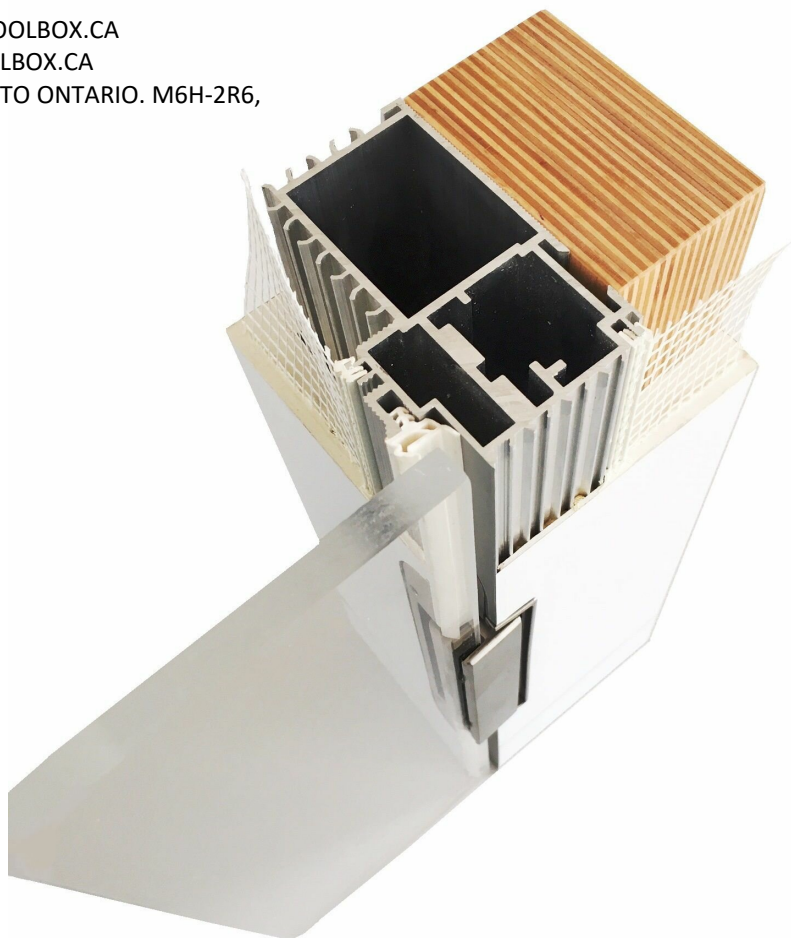

- (DE) Montageanleitung
- (IT) Istruzioni d'assemblaggio
- (EN) Assembly instructions
- (FR) Manuel d'assemblage

# TCG



Beim Profil TCG handelt es sich um Aluminiumprofile zur Fertigung von FRAMELESS Ganzglastüren für den Massiv- und Trockenbau. Die Profile können als Standard- als auch raumhohe Glastüren mit einer Stärke von 8 und 10 mm verbaut werden.

Die Aluminiumprofile werden auf Kundenwunsch inkl. den entsprechenden Bohrungen für Scharniere und Schließblech gefertigt. Die Profile sind mit einer Schutzfolie versehen und im Set inkl. aller Montage und Befestigungselemente verpackt.

Die Türprofile bestehen aus einer rohen unbehandelten Aluminiumlegierung. Zement und seine Derivate produzieren, bei Nässe, alkalische Substanzen welche, wenn man diese auf der Oberfläche der Aluminiumlegierung arbeiten lässt, zu Korrosion führen kann. Deshalb wird empfohlen die Profile immer frei von Zement, Kleber und Fugenmaterial zu halten. Die Korrosion wird durch die empfohlene bauseitige Grundierung und Lackierung des Profils in Wandfarbe verhindert.



Il modello TCG è un profilo d'alluminio per porte di vetro a filo muro del tipo FRAMELESS per strutture massicce e a secco. I profili possono essere utilizzati sia per porte in vetro misure standard o porte fino al soffitto con spessore 8 e 10 mm.

Il telaio della porta viene prodotto secondo le esigenze del cliente come l'altezza, larghezza, spessore battente, numero delle cerniere, modello di cerniera e scontro per serratura. I profili sono muniti di una pellicola di protezione e vengono confezionati come kit, inclusi tutti gli accessori per un semplice e rapido montaggio.

I nostri profili porta consistono d'alluminio grezzo, non lavorato. L'alta umidità del cemento e dei suoi derivati producono sostanze alcaline che possono causare corrosioni. Per evitare questo consigliamo di tenere i profili sempre liberi di cemento, colle e altre sostanze corrosive. La corrosione può essere evitata anche verniciando i profili con delle apposite lacche. Tuttavia l'alluminio non è resistente a tutte le composte chimiche.



The aluminium profiles TCG are used to create FRAMELESS glass door for solid and dry constructions. The profiles can be installed as standard or room-high glass doors with a thickness of 8 and 10mm.

The profiles are made according the customer's requirements and supplied mitre cut with the appropriate holes for hinges and strike plates. There are provided with a protective film and are packed in a set including all assembly and fastening parts.

The door profiles are made out of raw untreated aluminium. Cement and his derivatives produce alkaline substances when getting wet, which can provoke corrosion if they have time to work on the surface of the aluminium alloy. We recommend to keep the profiles clear from cement, glue and joints material. The above mentioned corrosion will be prevented by the recommended priming and finishing of the profiles in wall colours.



Le profilé TCG est un profilé en aluminium pour la fabrication de portes tout en verre sans cadre pour la construction solide et sèche. Les profilés peuvent être fournis en tant que portes vitrées standard ou en tant que portes vitrées de hauteur intérieure d'une épaisseur de 8 et 10 mm peut être.

Les profils en aluminium sont fabriqués sur demande du client et sont livrés, coupés en onglet, avec les perçages correspondants qui sont requis pour les charnières et les fermetures. Ils sont munis d'un film protecteur et sont livrés par lots, accompagnés de toutes les pièces de montage et de fixation.

En cas d'humidité, le ciment et ses dérivés produisent des substances alcalines susceptibles d'engendrer de la corrosion si on les laisse agir à la surface de l'alliage d'aluminium. C'est la raison pour laquelle il est recommandé de toujours veiller à ce que les profils soient exempts de ciment, d'adhésif et de matériau de joint. Le maître d'ouvrage peut empêcher la corrosion par l'application recommandée sur le profil d'une couche de fond et d'une couche de peinture dans la couleur des murs.

### Detail/Dettaglio/Détail A

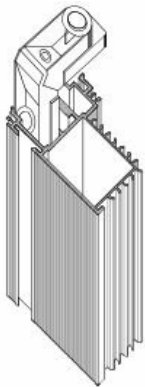

- DE 4 mm Sechskantschlüssel
- IT 4 mm vite esagonale
- EN 4 mm hexagonal wrench
- FR 4 mm clé hexagonal

**1**

- DE Eckverbinder bis zum Einrasten einschieben und Türzarge zusammensetzen (Detail A)
- IT Inserire gli angolari ed assemblare il telaio (dettaglio A)
- EN Insert the corner connector until they snaps in and assemble the door frame (detail A)
- FR Insérer les angles jusqu'à l'enclenchement et assemble les huisserie (détail A)

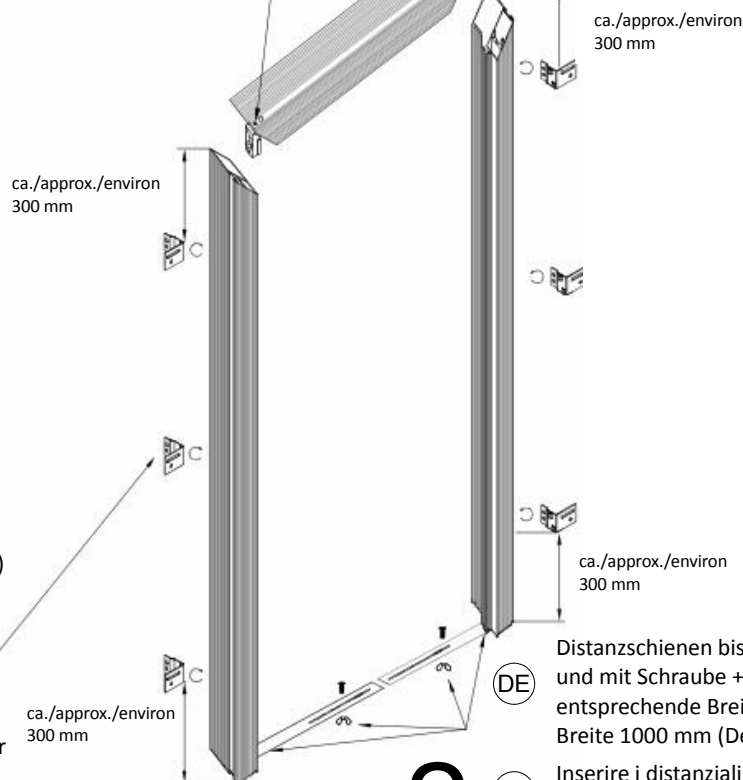

**3**

- DE Befestigungsbügel auf der Baustelle eindrehen (Detail C)
- IT Inserire le staffe di fissaggio (dettaglio C)
- EN Screw-in the wall fixing brackets at site (detail C)
- FR Tourner l'étrier de fixation sur le site (détail C)

**2**

- DE Distanzschienen bis auf Anschlag einbringen und mit Schraube + Flügelmutter auf entsprechende Breite fixieren. Maximale Breite 1000 mm (Detail B)
- IT Inserire i distanziali fino alla battuta e fissarli con vite e dado ad alette alla larghezza adeguata (dettaglio B)
- EN Insert the bottom spreader bars to the limit top and fix it with screws + wing nut on the appropriate width. Maximum width 1000 mm (detail B)
- FR Insérer le rail d'écartement jusqu'à la butée et fixer à la largeur souhaitée à l'aide d'une vis + écrou papillon. Largeur maximale 1000 mm (détail B)

### Detail/Dettaglio/Détail C

Befestigungsbügel/Staffe di fissaggio/Wall fixing brackets/Étrier de fixation  
Art. Nr./Item no. 13052

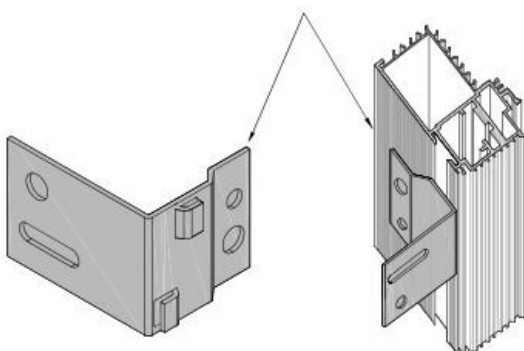

### Detail/Dettaglio/Détail B

Distanzschienen/Distanziali/Bottom spreader bar/Barre d'ecartement  
Art. Nr./Item no. 13053

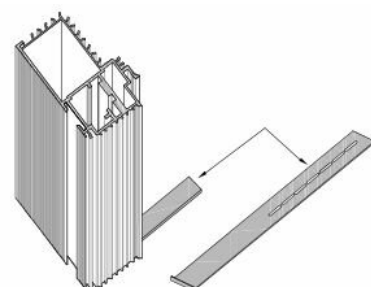



**Detail/Dettaglio/Détail E**

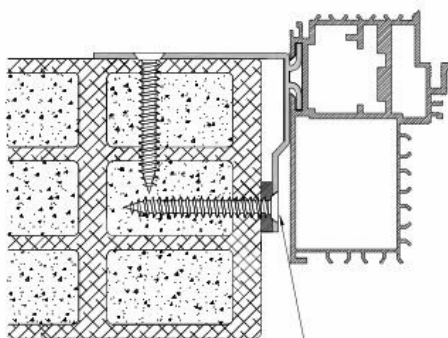

**Detail/Dettaglio/Détail D**

Bohrung für Befestigungsbügel/  
 Perforazione per le staffe di fissaggio/  
 Drilling for the wall fixing brackets/  
 Étrier de fixation

- 4**
- DE Montage der Zarge (Detail E)
  - IT Montare il telaio (dettaglio E)
  - EN Mounting the frame (detail E)
  - FR Montage du cadre (détail E)

Bohrung/Perforazione/  
 Drilling/Forage  
 16 x 7 mm

Bohrung/Perforazione/  
 Drilling/Forage  
 30 x 14 mm

Meterriss/Livellometrico/  
 Meter level/Trait de niveau

Meterriss/Livellometrico/  
 Meter level/Trait de niveau

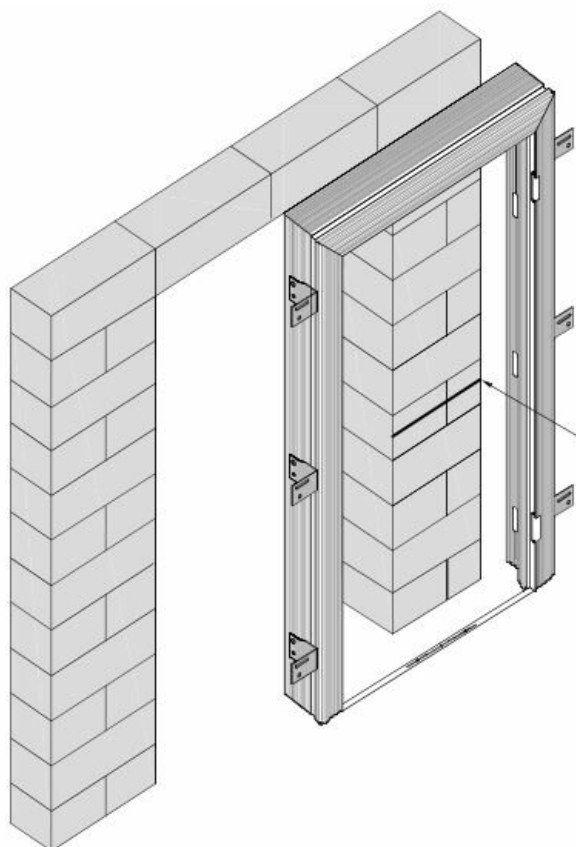

- 5**
- DE Tüorzarge in die Maueröffnung einsetzen, auf Meterriss einrichten und befestigen (Detail D)
  - IT Inserire il telaio nel foro muro e adattarlo al livello metrico e fissarlo (dettaglio D)
  - EN Insert frame in the wall opening and set it up on the meter and fix it level (detail D)
  - FR Insérez le cadre de porte dans l'ouverture du mur, ajustez selon le plan au mètre et fixez-le (détail D)

- 6** **DE** Türzarge horizontal und vertikal ausrichten und an allen Befestigungsbügeln verschrauben. Zuerst wandseitig befestigen danach leibungsseitig hinterfütern und fixieren (Detail F)
- IT** Regolare e spessorare il telaio a piombo ed avvitarlo alle staffe di fissaggio. (dettaglio F)
- EN** Adjust the frame horizontally and vertically. Screw it together with the wall fixing brackets. At first install it at wall side and then fix and backfill it at the reveal side (detail F)
- FR** Positionner le châssis horizontalement et verticalement. Fixer avec les étriers de fixation. D'abord l'installer du côté de mur et puis fixer et recouvre dans l'embrasure (détail F)

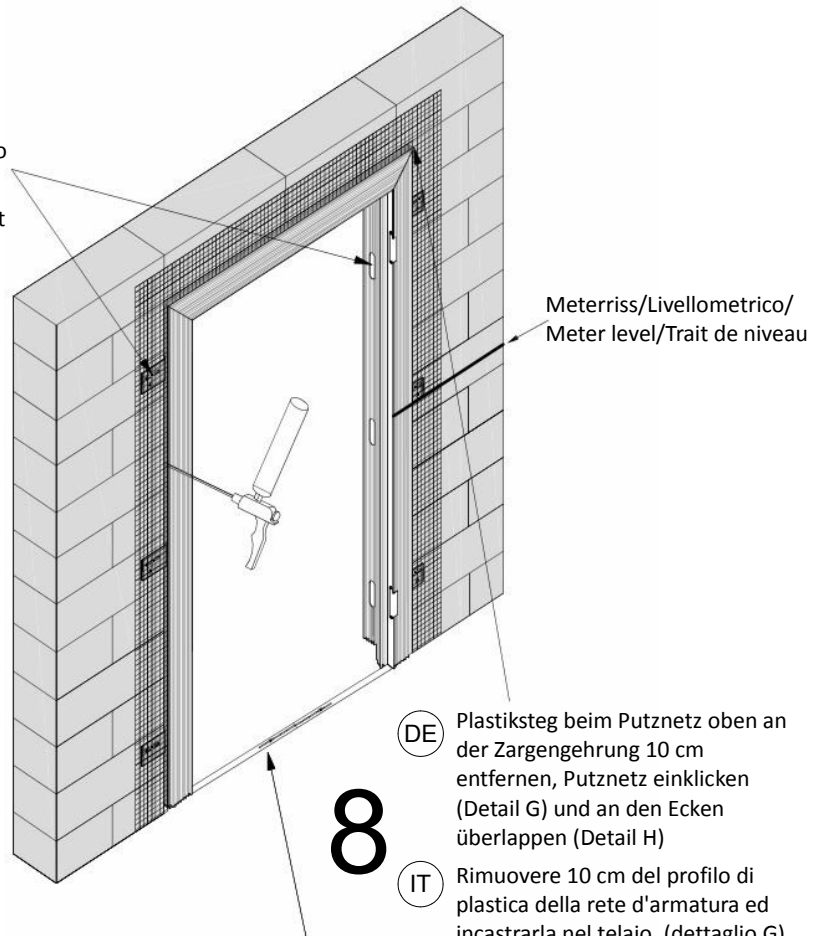

- 7** **DE** Nach Befestigung die Zarge vollvolumig mit handelsüblichen PU-Montagekleber hinterfüllen
- IT** Dopo il fissaggio riempire gli spazi rimanenti con una colla poliuretanaica
- EN** After fixation of the frame backfill it completely with a commercial PU-mounting adhesive
- FR** Surmoussage le cadre avec une colle de montage PU commerciale après l'assemblage

- DE** Plastiksteg beim Putznetz oben an der Zargengehrung 10 cm entfernen, Putznetz einklicken (Detail G) und an den Ecken überlappen (Detail H)

- IT** Rimuovere 10 cm del profilo di plastica della rete d'armatura ed incastrarla nel telaio. (dettaglio G) Sovrapporre la rete negli angoli (dettaglio H)

- EN** Cut 10 cm of the plastic profile of the mesh at the mitre spot and click it in (detail G) and overlap the mesh on the angles (detail H)

- FR** Détacher 10 cm de profil en plastique du filet support d'enduit et encliqueter (détail G) et veiller à ce que le filet se chevauche dans les coins (détail H)

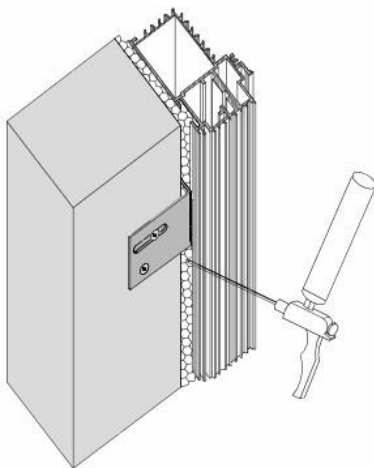

- 9** **DE** Nach Befestigung und Hinterfüllung der Zarge die Distanzschiene entfernen (Detail I)
- IT** Rimuovere il distanziale dopo aver fissato e riempito gli spazi vuoti del telaio (dettaglio I)
- EN** After fixing and backfilling of the frame remove the bottom spreader bar (detail I)
- FR** Retirer le rail d'écartement après l'assemblage et la soumoussage (I)détail I)

### Detail/Dettaglio/Détail F

Dübel/Tassello/Dowel/Cheville



Schrauben/Viti/Screws/Clés

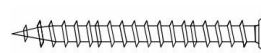

Rahmenschrauben/Viti per telai/Frame screws/Clés de cadre



**Detail/Dettaglio/Détail G**

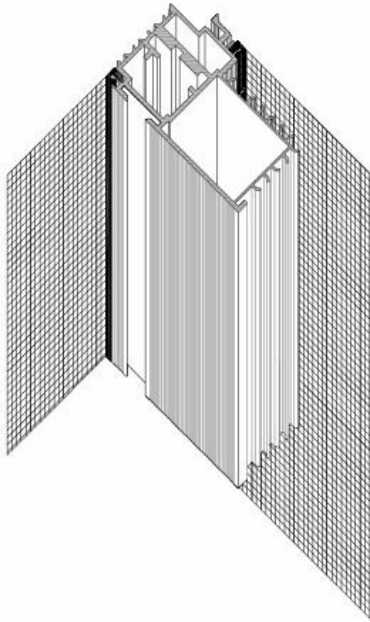

**Detail/Dettaglio/Détail H**

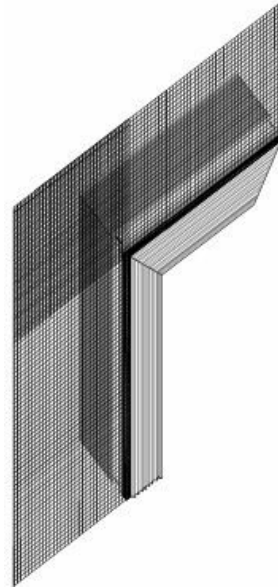

**Detail/Dettaglio/Détail I**

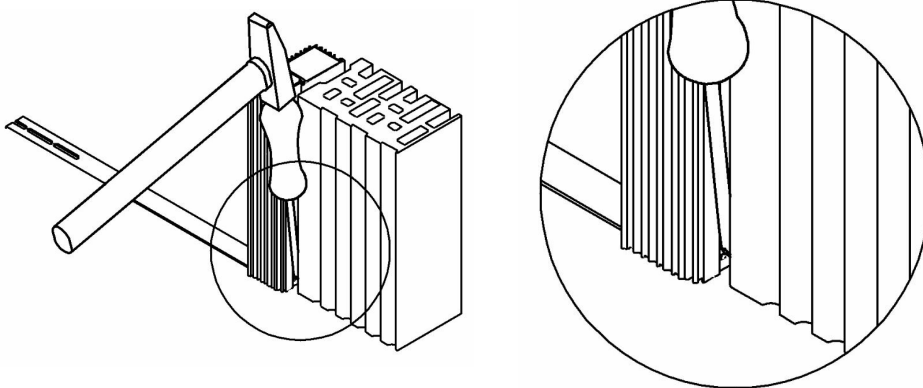

# 10

- DE Putznetz nach vorne klappen, Grundputz vollflächig auftragen und alle Hohlräume schließen
- IT Applicare l'intonaco su tutte le superficie senza lasciare camere d'aria dietro la rete d'armatura
- EN Fold the mesh forward, fully add the base plaster and close the cavities
- FR Basculer le filet an avant, recouverter entièrement d'enduit de fond et fermer les cavités

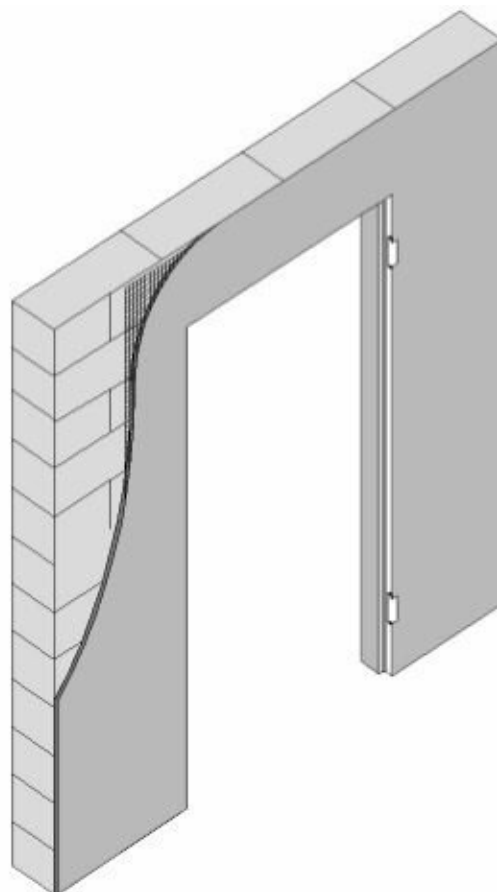
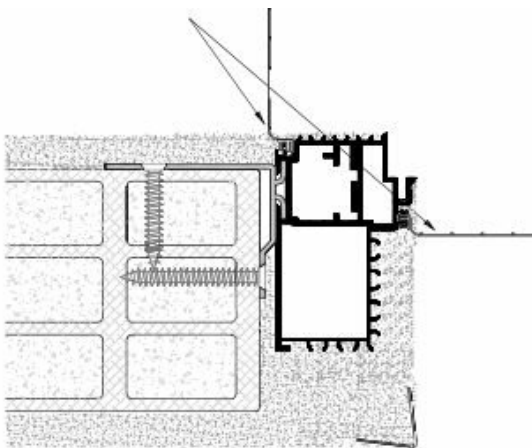

# 11

- DE Putznetz in Grundputz einbringen und einarbeiten
- IT Inserire la rete d'armature dell'intonaco
- EN Insert and include the mesh to the base plaster
- FR Insérer et plâtrer le filet sur l'enduit de fond

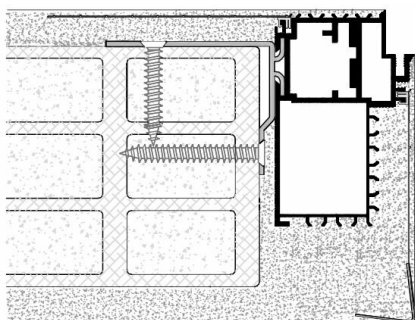
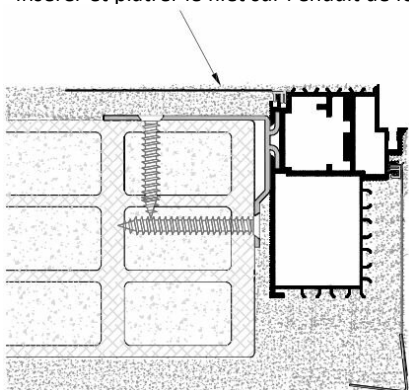

# 13

- (DE) Türrahme horizontal und vertikal ausrichten und an Ständerbau verschrauben (Detail D)
- (IT) Allineare il telaio orizzontalmente e verticalmente e avvitarlo alla struttura verticale (dettaglio D)
- (EN) Align the frame horizontally and vertically and screw it to the upright construction (detail D)
- (FR) Aligner le cadre horizontalement et verticalement et le visser à la construction (détail D)

# 12

- (DE) Türrahme in die Öffnung einsetzen und auf Meterriss ausrichten
- (IT) Inserire il telaio nell'apertura e adattarlo al livello metrico
- (EN) Insert frame in to the opening and set it up on the meter level
- (FR) Insérer le cadre de porte dans l'ouverture et l'aligner sur le plan au mètre

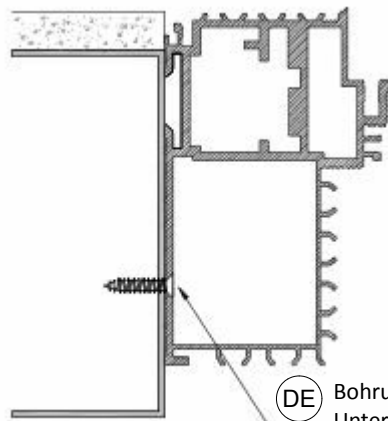
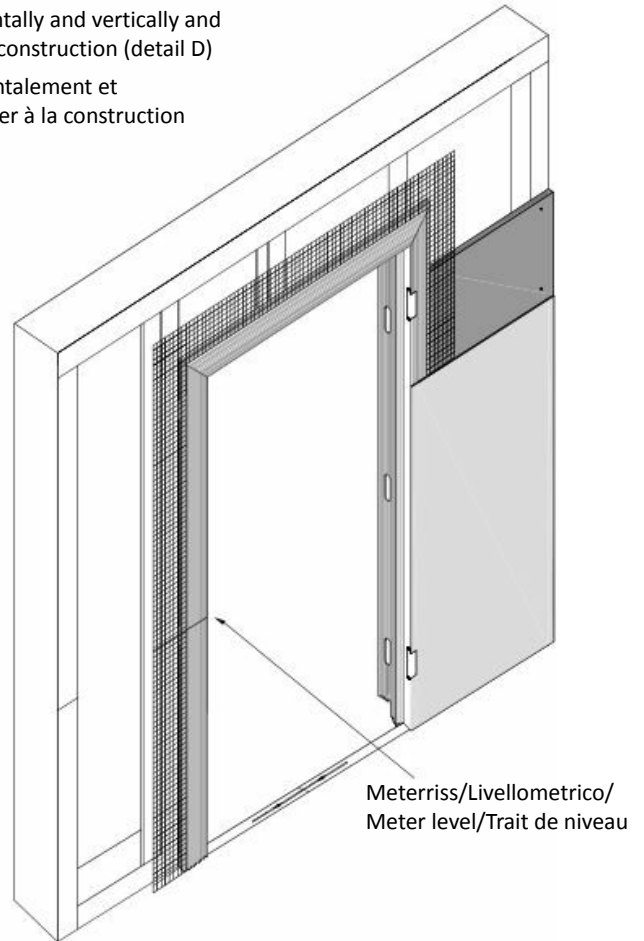
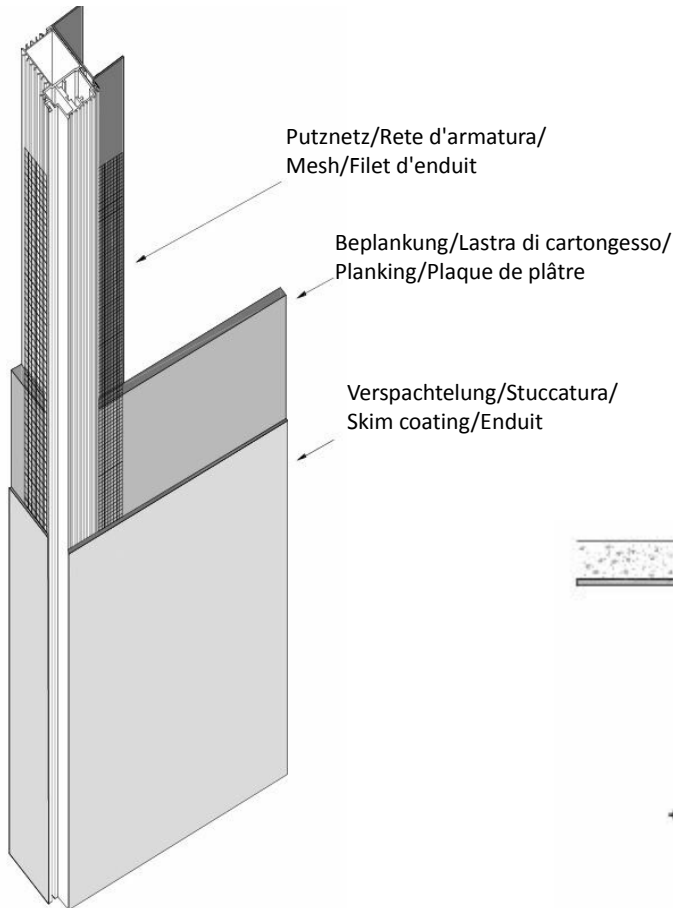

- (DE) Bohrung für Befestigung an Unterkonstruktion (Detail D)
- (IT) Foro per il fissaggio alla sottostruttura (dettaglio D)
- (EN) Drilling for fastening the substructure (detail D)
- (FR) Trou pour la fixation à la sous-structure (détail D)

# 14

- DE Den Gehäusedeckel vorsichtig mit einem Messer vom Verputz lösen
- IT Rimuovere con attenzione il coperchio dell'alloggiamento dall'intonaco con un coltello
- EN Carefully remove the housing cover from the plaster with a knife
- FR Retirer avec précaution le couvercle du boîtier du plâtre à l'aide d'un couteau

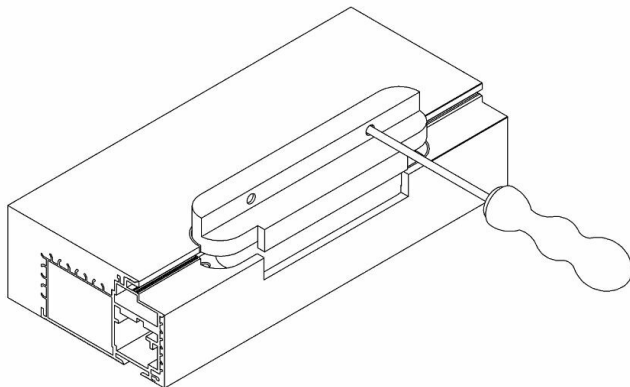
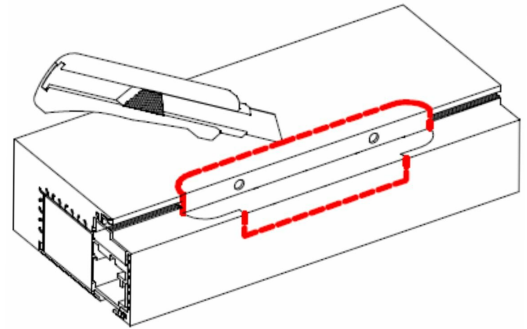

# 15

- DE Gehäusedeckel mit Hilfe eines Schraubenzieher vorsichtig herausnehmen
- IT Rimuovere con cautela il coperchio della custodia con un cacciavite
- EN Carefully remove the housing cover using a screwdriver
- FR Retirer soigneusement le couvercle du boîtier à l'aide d'un tournevis

# 16

- DE Nach entfernen des Gehäusedeckels können nun die Schrauben mit einem Inbus-Schraubendreher entfernt werden. Der Gehäuseboden bleibt in der Zarge
- IT Dopo aver rimosse il coperchio della custodia, le viti possono ora essere rimosse con una cacciavite a brugola. La parte inferiore dell'alloggiamento rimane nel telaio
- EN After removing the housing cover, the screws can be removed with an Allen screwdriver. The housing base remains in the frame
- FR Après avoir retiré le couvercle du boîtier, les vis peuvent maintenant être retirées à l'aide d'un tournevis Allen. Le fond du boîtier reste dans le cadre

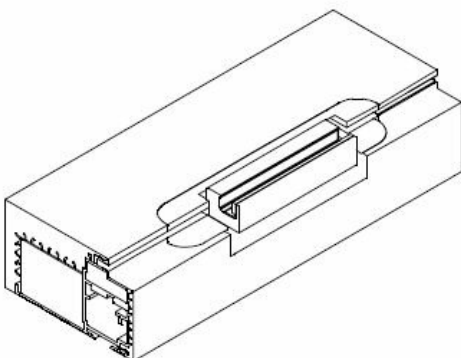
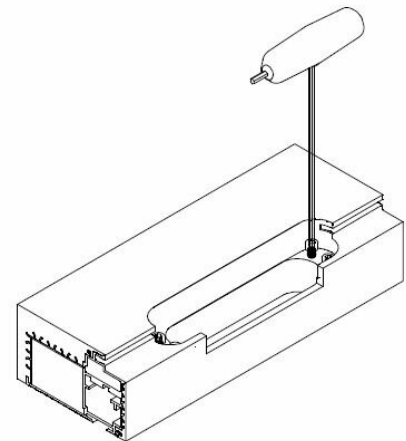

# 17

- DE Scharnier einlegen und fixieren
- IT Inserire la cerniera e fissarla
- EN Insert the hinge and fix it
- FR Insérez la charnière et fixez-la avec

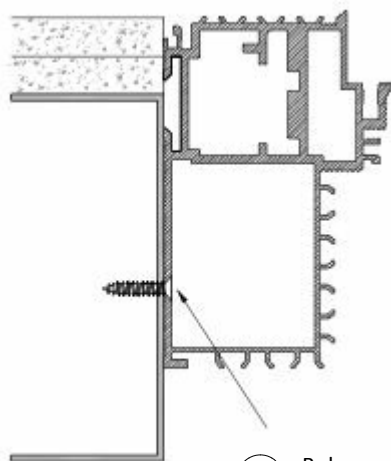
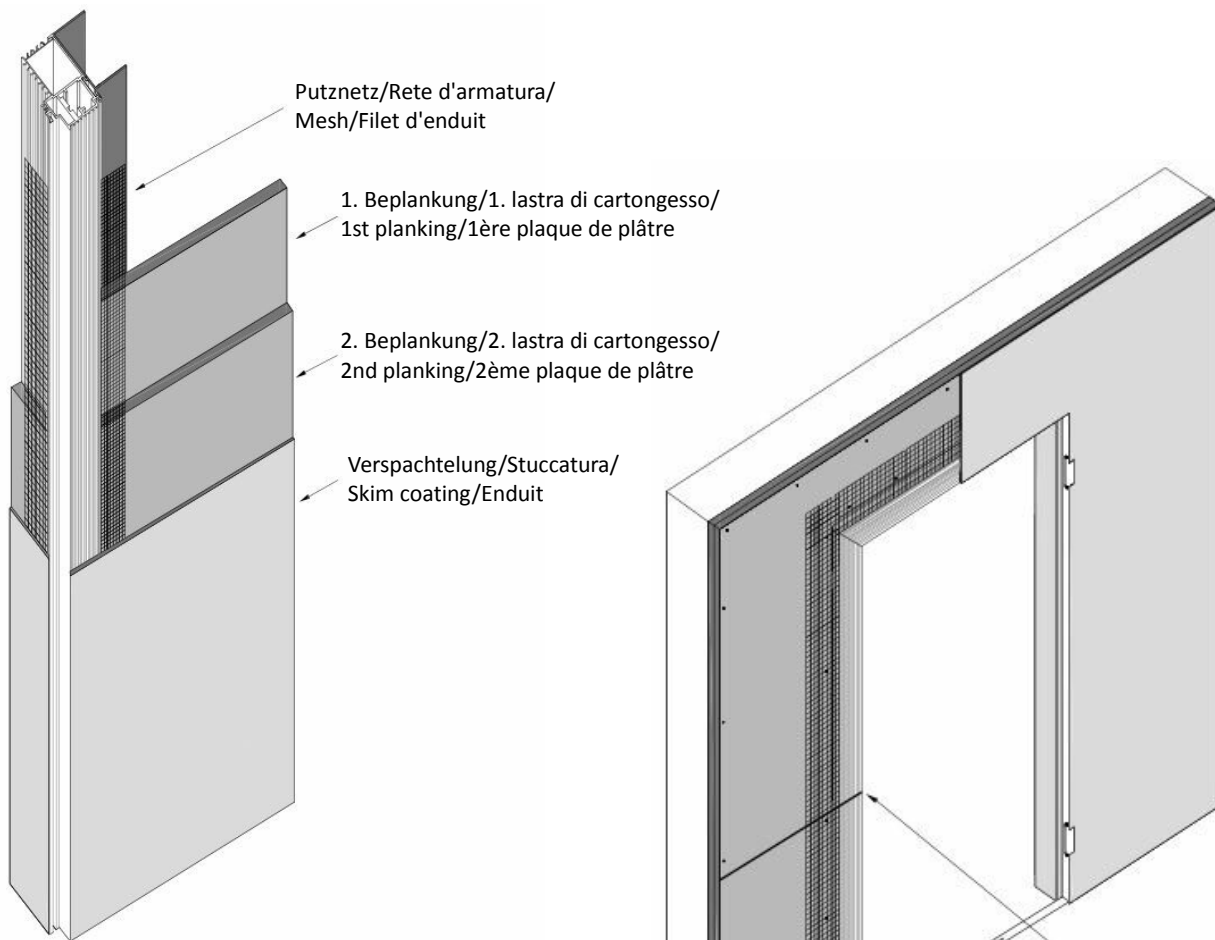

- DE Nach Befestigung und Hinterfüllung der Zarge die Distanzschiene entfernen (Detail I)
- IT Rimuovere il distanziale dopo aver fissato e riempito gli spazi vuoti del telaio (dettaglio I)
- EN After fixing and backfilling of the frame remove the bottom spreader bar (detail I)
- FR Retirer le rail d'écartement après l'assemblage et la soumoissance (détail I)

- DE Bohrung für Befestigung an Unterkonstruktion (Detail D)
- IT Foro per il fissaggio alla sottostruttura (dettaglio D)
- EN Drilling for fastening the substructure (detail D)
- FR Trou pour la fixation à la sous-construction (détail D)

Mod. TCG

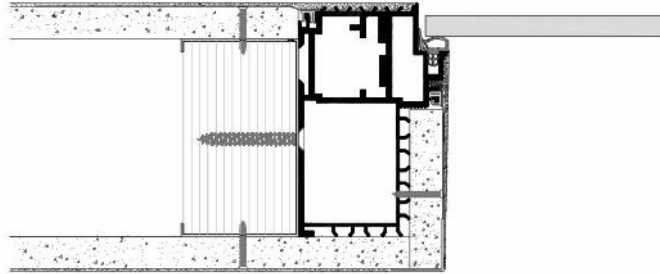

- Ⓛ DE Einfachbeplankung
- Ⓛ IT Singola lastra
- Ⓛ EN Single layer
- Ⓛ FR Single plaque de plâtre

Mod. TCG

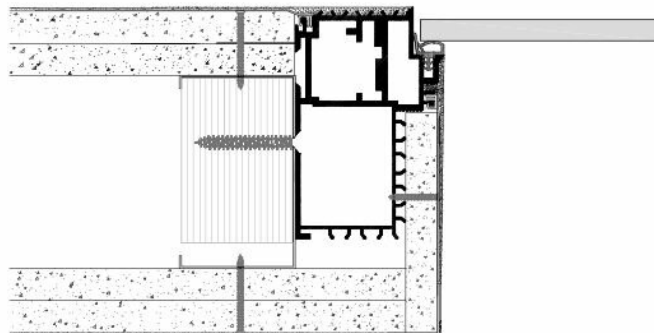

- Ⓛ DE Doppelbeplankung
- Ⓛ IT Doppia lastra
- Ⓛ EN Double layer
- Ⓛ FR Double plaque de plâtre



.....

.....

.....

.....

.....

.....

.....

.....

.....

.....

.....

.....

.....

.....

.....



~ your choice of modern living ~

Thank you for having chosen our systems

.....

.....

.....

.....

.....

.....

.....

.....

.....

.....

.....

.....



~ your choice of modern living ~

Thank you for having chosen our systems

Frameless  
Flush  
Shadowgap  
Solutions

**AGS**systems

THEINVISIBLETOOLBOX.ca

SOUND PRINCIPLES FOR MINIMAL CONSTRUCTION  
By KOMETSENSE INC. 988 Albers St. Toronto, Ontario, M8H 1Z8  
WWW.THEINVISIBLETOOLBOX.CA WWW.KOMETSENSE.COM  
INFO@THEINVISIBLETOOLBOX.CA Phone: 647.800.4105

**AGS**systems

~ your choice of modern living ~

Thank you for having chosen our systems

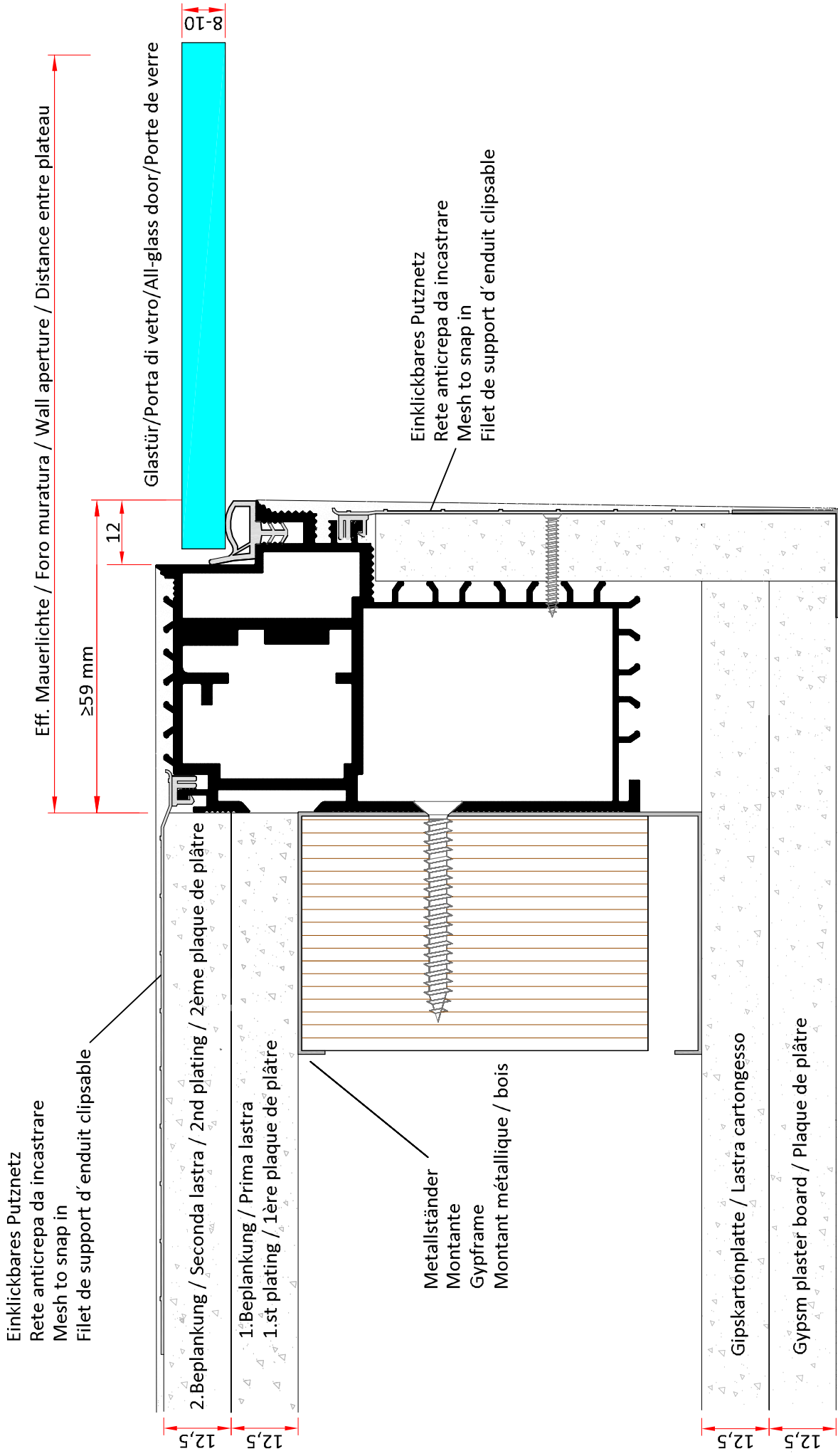

FOR ANY TECHNICAL QUESTIONS PLEASE CONTACT US. WE ARE ABLE TO OFFER CAD FILES OF APPLICATION DRAWINGS PER ANY RELEVANT WALL ASSEMBLY. ADDITIONALLY YOU WILL FIND MORE LOCAL CONSTRUCTION RELEVANT EXAMPLES ON OUR WEBSITE. THANKYOU!

AGS Systems - Canada. By THEINVISIBLETOOLBOX  
PH. 647.5004103 | E. INFO@THEINVISIBLETOOLBOX.CA WWW.THEINVISIBLETOOLBOX.CA  
36 ALBERTA AVE. TORONTO ONTARIO. M6H-2R6, CANADA.

AGS-Systems - 39025 Naturno (Italy)	
Drawing	TCG Art.nr. 10160
Scala 1:1	Date 06 03 2018
	Modified
AGS-systems - 39025 Naturno (Italy) Stava 47B tel. 0039 0473 666376 - info@ags-systems.com	

This drawing is copyright by AGS-systems and exclusive, protected by law and cannot reproduced without written affirmation

Einklickbares Putznetz  
 Rete anticrepa da incastrare  
 Mesh to snap in  
 Filet de support d'enduit clipsable

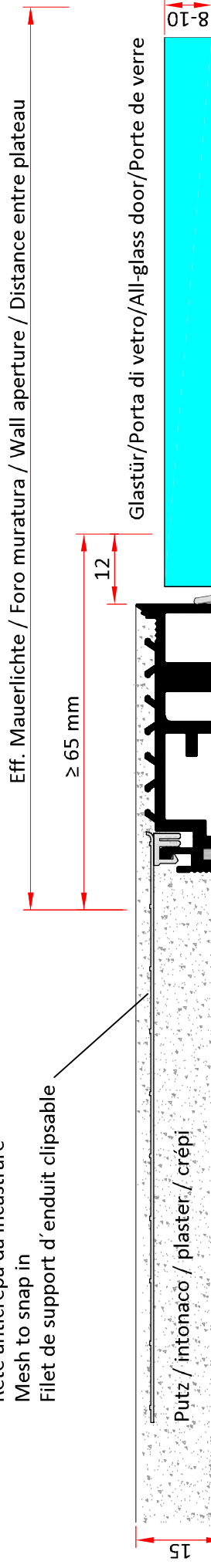

Einklickbares Putznetz  
 Rete anticrepa da incastrare  
 Mesh to snap in  
 Filet de support d'enduit clipsable

FOR ANY TECHNICAL QUESTIONS PLEASE CONTACT US. WE ARE ABLE TO OFFER CAD FILES OF APPLICATION DRAWINGS PER ANY RELEVANT WALL ASSEMBLY. ADDITIONALLY YOU WILL FIND MORE LOCAL CONSTRUCTION RELEVANT EXAMPLES ON OUR WEBSITE. THANKYOU!

AGS Systems - Canada. By THEINVISIBLETOOLBOX  
 PH. 647.5004103 | E. INFO@THEINVISIBLETOOLBOX.CA WWW.THEINVISIBLETOOLBOX.CA  
 36 ALBERTA AVE. TORONTO ONTARIO. M6H-2R6, CANADA.

AGS-Systems - 39025 Naturno (Italy)	
Drawing	TCG Art.nr. 10160
Scala 1:1	Date 06 03 2018
	Modified
AGS-systems - 39025 Naturno (Italy) Stava 47B tel. 0039 0473 666376 - info@ags-systems.com	

This drawing is copyright by AGS-systems and exclusive, protected by law and cannot reproduced without written affirmation

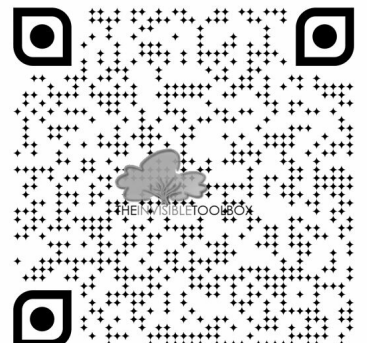
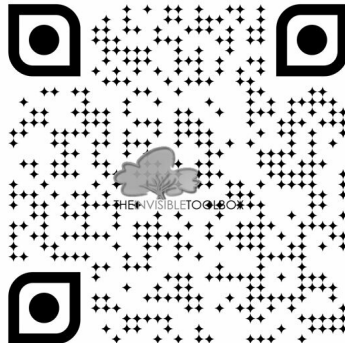
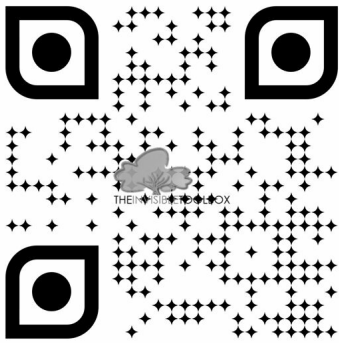

Frameless  
Flush  
Shadowgap  
Solutions

**TAGS** systems

By  
**THEINVISIBLETOOLBOX.ca**

SOUND PRINCIPLES FOR MINIMAL CONSTRUCTION  
By KOMETSENSE Inc. #36 Alberta Ave, Toronto Ontario. M6H-2R6  
WWW.THEINVISIBLETOOLBOX.CA WWW.KOMETSENSE.COM  
INFO@THEINVISIBLETOOLBOX.CA Phone: 647.500.4103

